

# TURNING THE XRAY ON THE WILLYS EIGHT

## Retail Sales Manager's Film Service

COPYRIGHTED 1928 BY WILLYS-OVERLAND, INC.

One in a series of original filmstrips preserved for their historical value and presented to the members of the  
[Willys Overland Knight Registry](#)

Assembled September 2000 by Spence Fowler  
(member #4536)

[sdf@att.net](mailto:sdf@att.net)

<http://sdf.home.att.net>



Turning the X-RAY on

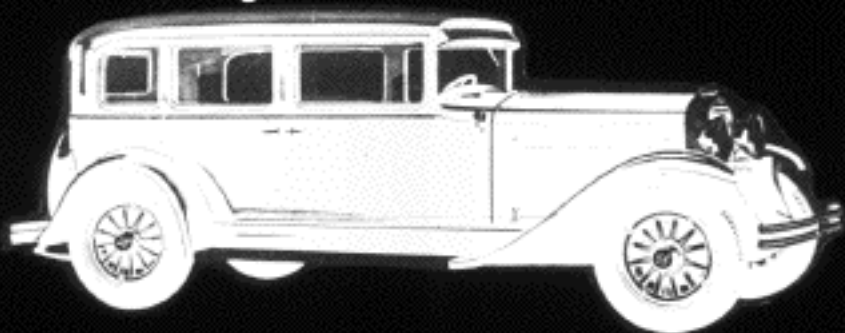

the WILLYS 8.



We are presenting the inside story of the new Willys 8-80 because beneath its beauty of line and luxurious appointments, there is engineering design which establishes it superior to other cars in its price class.



Mechanically, the Willys 8 is a dramatic tribute to its ancestry extending over a quarter of a century of leadership in building fine cars.



Every thinking buyer should realize that the foundation of value, performance and satisfaction rests on the mechanical construction of the car.

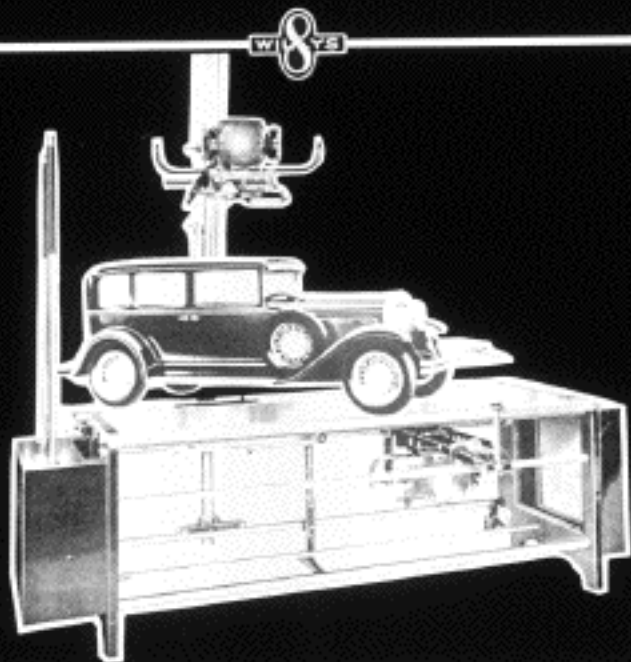

Now let us turn the X-ray on the Willys 8

5

WILLYS

Willys Overland invites a searching examination of this marvelous motor.

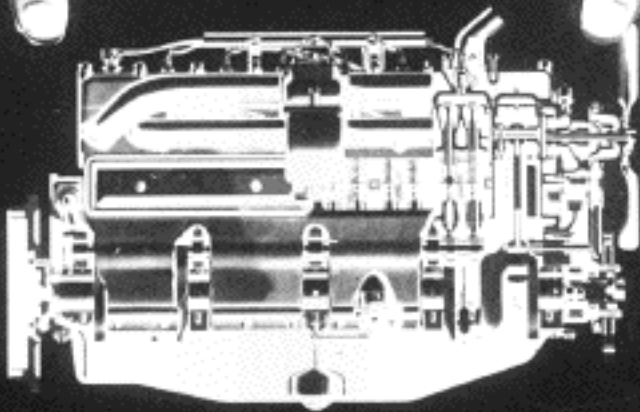

Only the volume manufacturing methods resulting from world wide acceptance could make such a power plant possible at such a low price.





Force-feed, full pressure lubrications assuring long life  
and positive oil supply to every frictional surface.

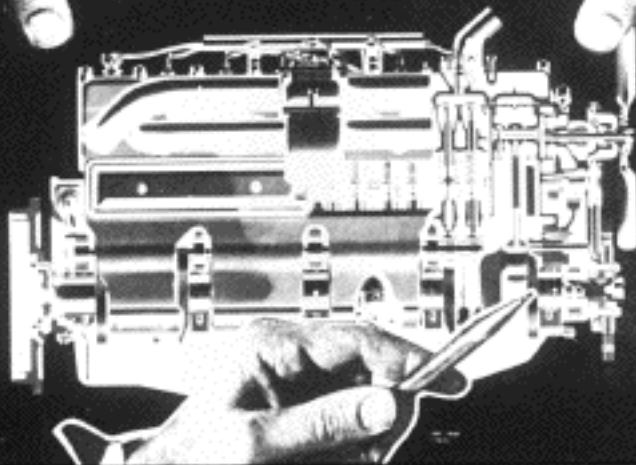

WILLYS  
8  
YE

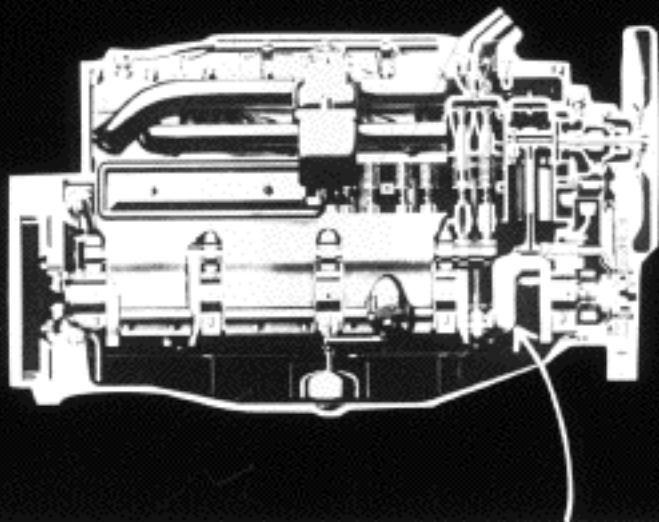

Massive crankshaft drop forged, heat treated and counterbalanced to provide maximum smoothness.

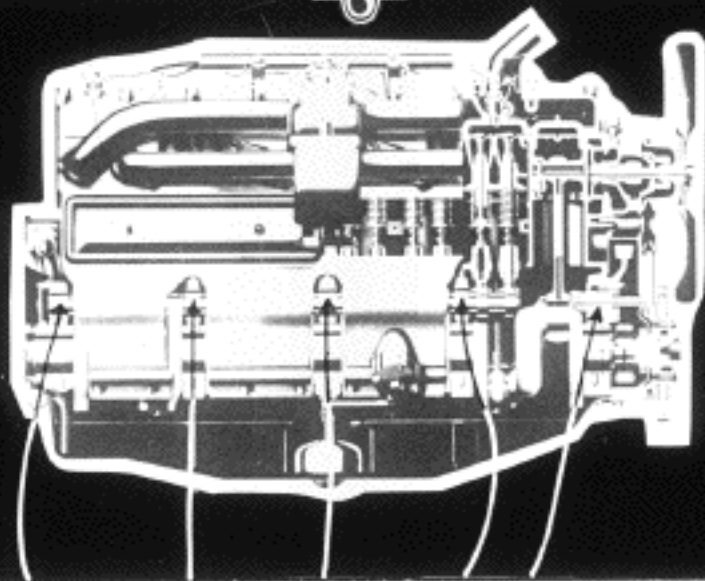

Five large bearings support the heavy camshaft as it turns on oil under pressure.



Connecting rods are rifle drilled to carry oil under pressure to the wrist pin bearing.

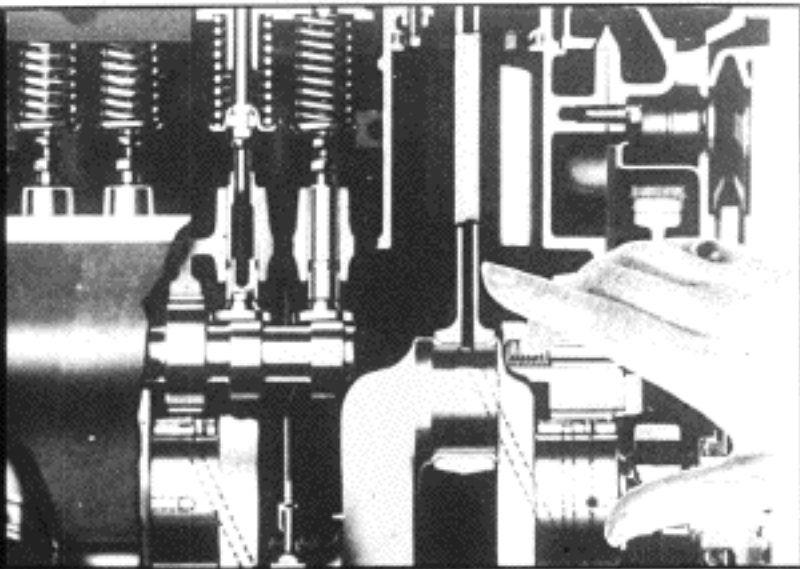



Thoroughness of lubrication is typical of Willys-Overland's thoroughness of design - even the timing chain is lubricated under pressure.

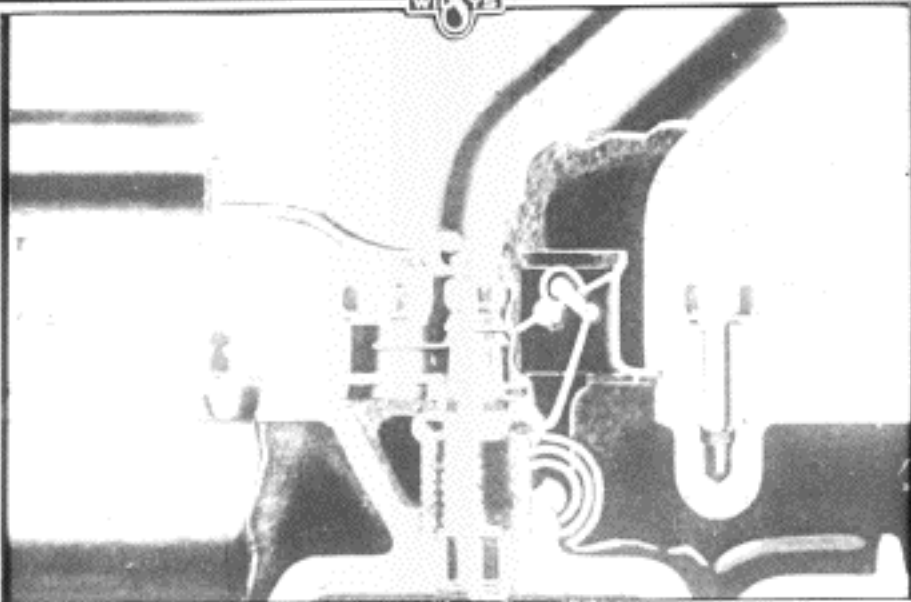

Thermostatically controlled cooling system assures quick warm up and guards against dilution.

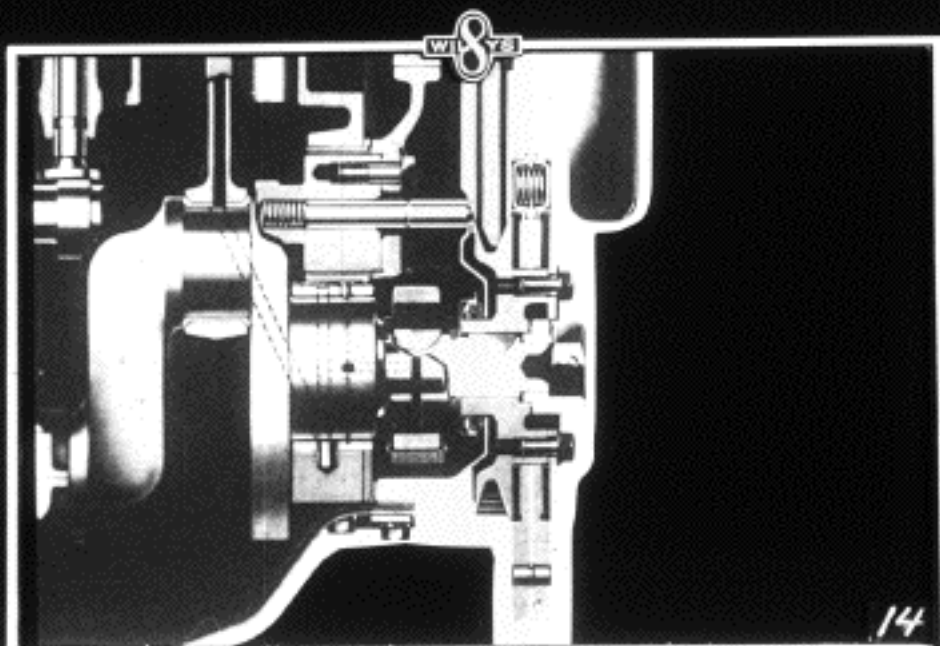

This vibration dampener smooths out the slightest tremor of vibration thus providing increased smoothness.

W 8 YS

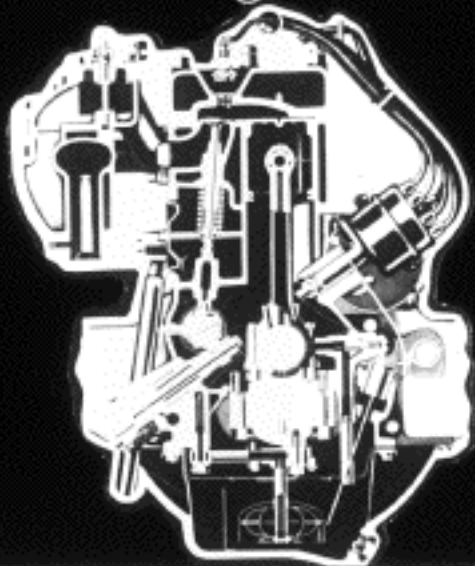

Here again our X-Ray presentation shows fineness of design and superlative engineering.





Notice the latest type of combustion chamber, inherent smoothness, increased compression and greater economy.

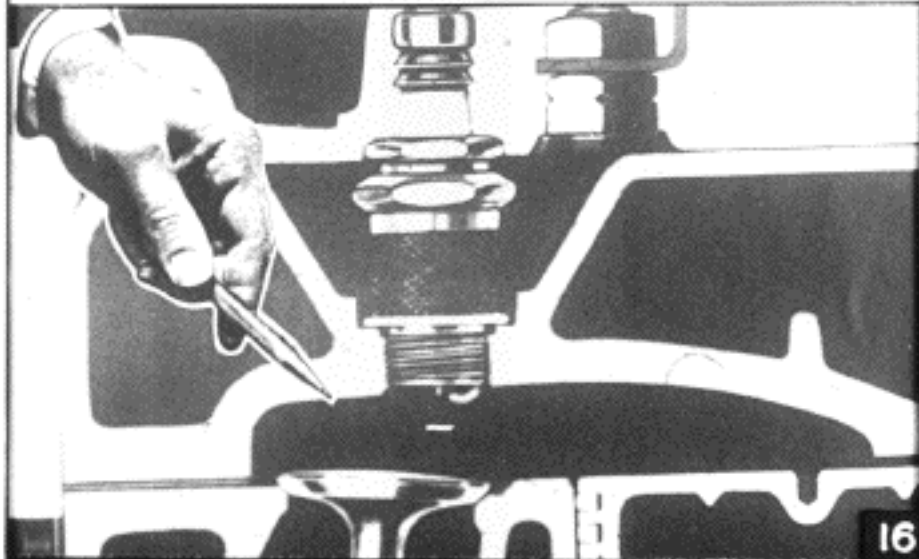

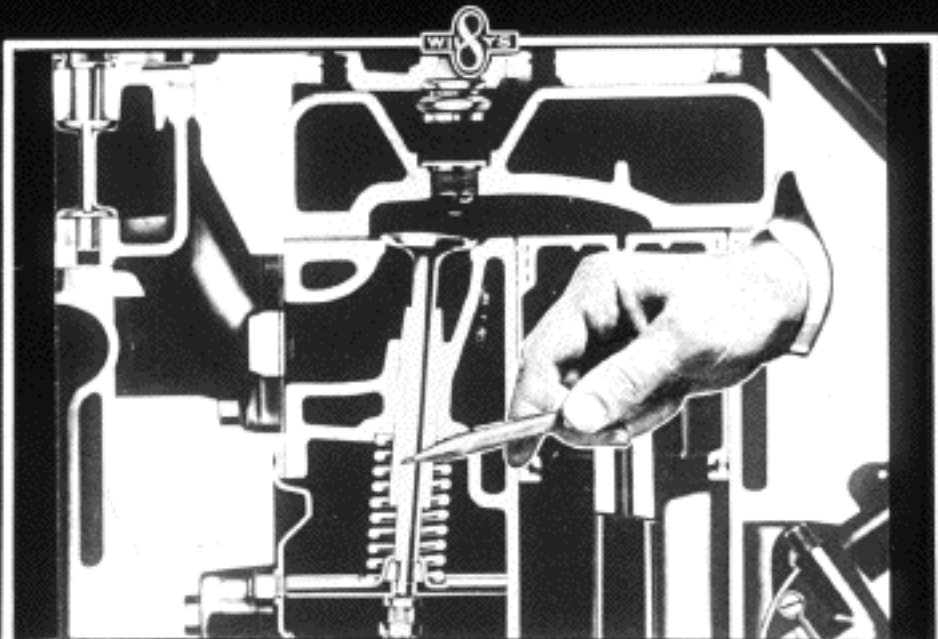

The scientific design of the valves gives free sweep incoming and exhaust gases.

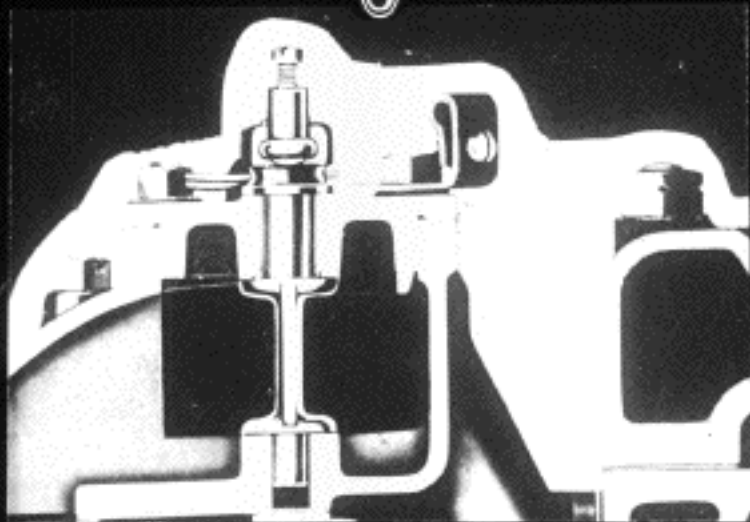

Many cars are without this adjustable heat control but it is standard equipment on the Willys 8-80.



Every part of the Willys  
8 motor and its equip-  
ment is designed to exceed  
your expectations of  
**PERFORMANCE.**



Acceleration, Power, Economy,— all in one  
with this latest type Tillotson carburetor.

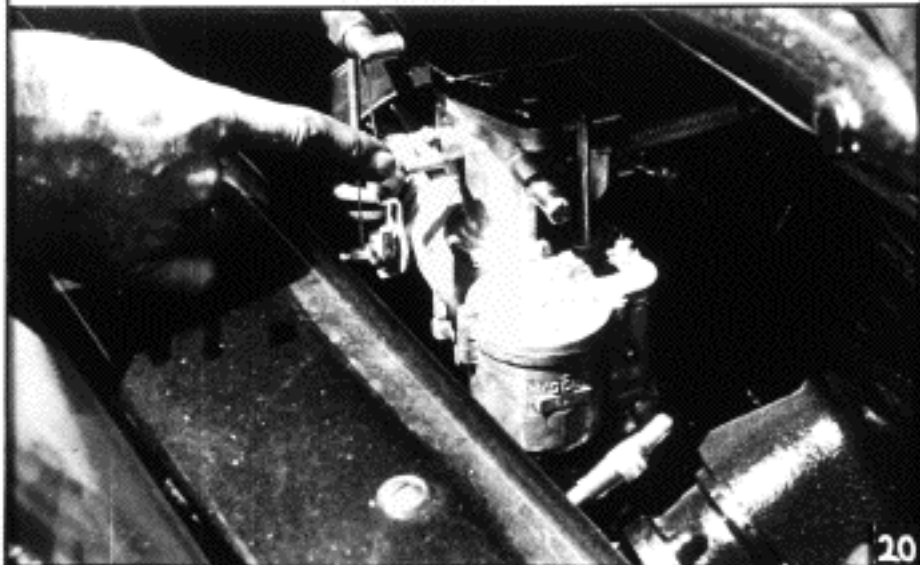

WILLYS

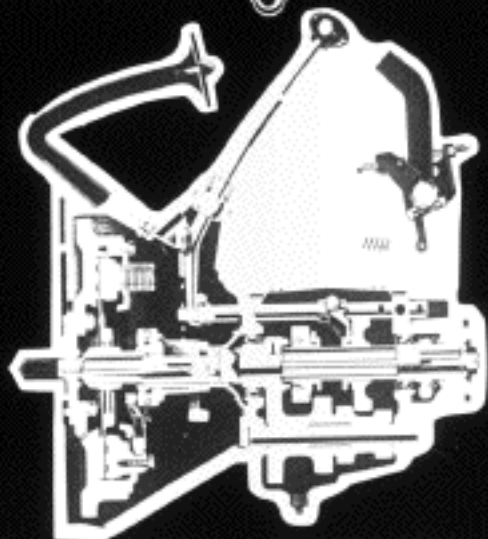

The clutch is as velvet smooth as the motor itself. It is the famous Borg and Beck, single plate dry disc type.

W 8 YS

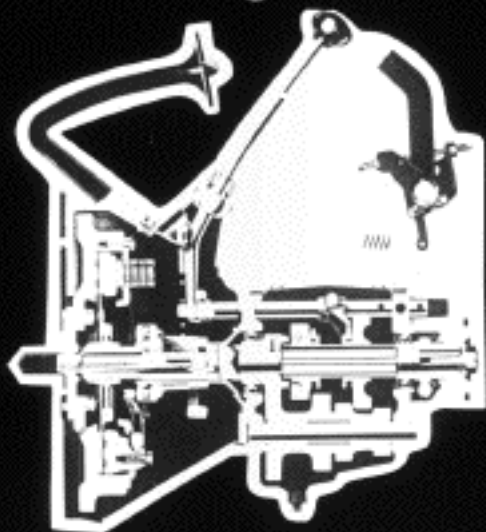

Transmission is geared to turn 8-80  
POWER into 48 miles an hour in second.



You will never see nor  
hear the inside of the  
Willys 8 axle.

Let us X-ray it  
for you.



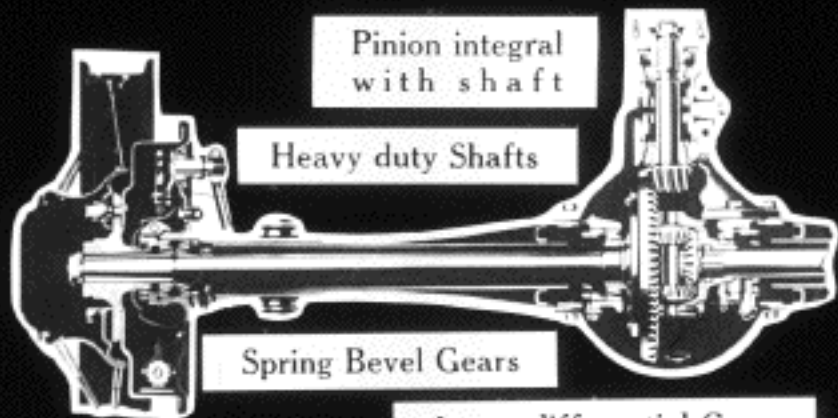

Pinion integral  
with shaft

Heavy duty Shafts

Spring Bevel Gears

Large differential Gears

8 Timken Bearings



Every Willys 8 rear axle  
is tested for silence  
before it becomes part  
of the chassis.



Willys Eight  
front axles  
are as  
carefully engineered  
as the rear.

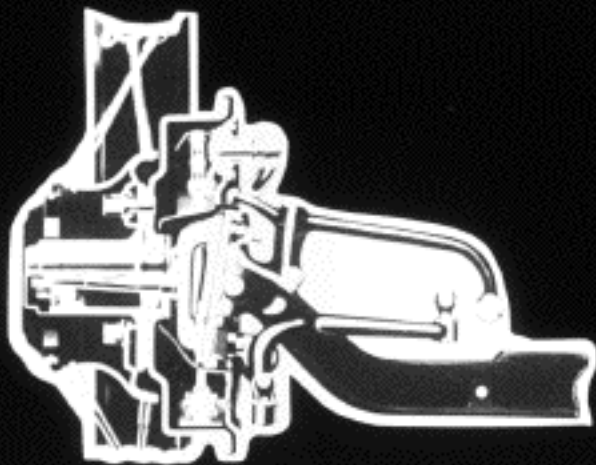

Drop forgings, Timken bearings, heavy construction,  
are quality features in keeping with Willys 8 design.



Internal expanding four  
wheel brakes make Willys  
8 power~USABLE POWER.



187 Square Inches  
of braking surface  
assure positive,  
almost effort -  
less control of  
the 80 horsepower.



And now let us  
inspect the  
8-80 chassis .



It is the sum total of 24 years of automobile engineering experience, months and months of testing and all the resources of the entire Willys Overland organization.



4 hydraulic double acting Shock Eliminators

15 to 1 Steering Gear.

Double Drop Frame

92 inches of Spring Suspension.

120 inch Wheelbase

7 heavy cross members,  
two of which are tubular.

Tryon Shackles



The Willys 8 comes to you after thousands of miles of gruelling tests under every conceivable condition.

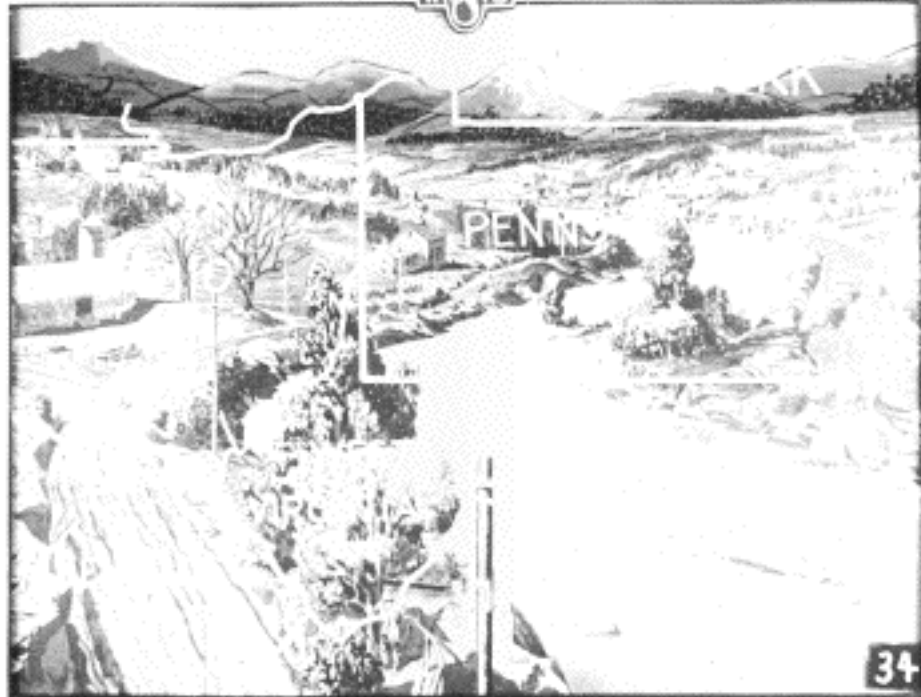



No man-made proving ground could duplicate the rugged conditions which Willis-Overland engineers search out in the heart of the Appalachians.



And Now as we take the  
Willys 8 out from under  
the X-ray machine we  
present it to you as the  
~~~Eight of Eights.

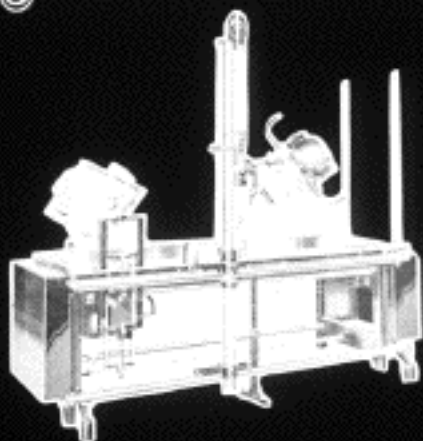

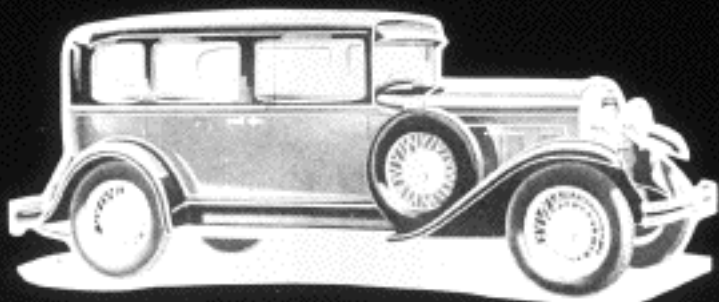

The only real way to experience the thrill of its performance is to let it speak for itself on the road. Take it out and make it do the things you want a car to do and in the way you want them done.

COPYRIGHTED 1930 BY WILLYS-OVERLAND, INC.

The End  
To rewind, start at this end dull side out holding film by edges. Be sure to keep fingers off dull side of film.

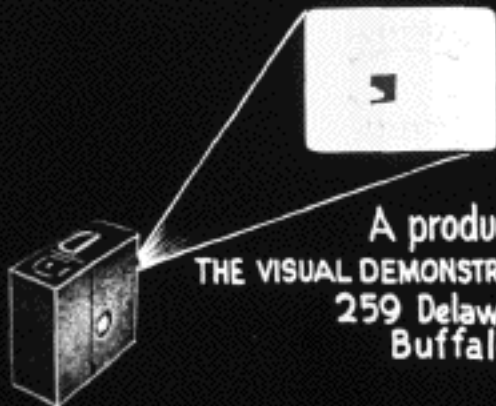

A production of  
THE VISUAL DEMONSTRATION SYSTEM, Inc.  
259 Delaware Ave,  
Buffalo, N.Y.

*Retail Sales Manager's Film Service.*